

AOYUE®

Replacement Air Nozzles

SGL SERIES

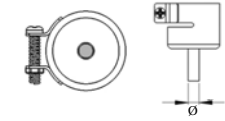

| MODEL # | NOZZLE SIZE Ø |
|---------|---------------|
| 1124 | 2.4mm |
| 1130 | 4.4mm |
| 1194 | 6mm |
| 1195 | 8mm |
| 1196 | 7mm |
| 1197 | 9mm |
| 1198 | 12mm |

1325 Air Nozzle

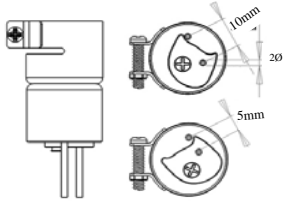

1142 Air Nozzle

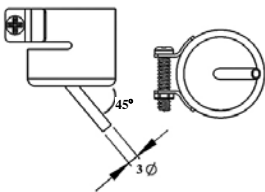

SIL SERIES

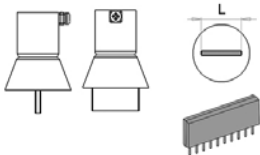

| MODEL # | IC SIZE | L (mm) |
|---------|---------|--------|
| 1191 | SIP25L | 26 |
| 1192 | SIP50L | 52.5 |

BGA SERIES

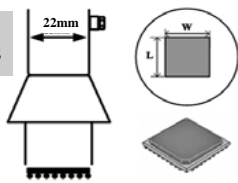

| MODEL # | IC SIZE | L (mm) | W (mm) |
|---------|---------|--------|--------|
| 1010 | 9×9mm | 10 | 10 |
| 1313 | 12×12mm | 13 | 13 |
| 1616 | 15×15mm | 16 | 16 |
| 1919 | 18×18mm | 19 | 19 |
| 2828N | 27×27mm | 28 | 28 |
| 3030N | 29×29mm | 30 | 30 |
| 3232W | 31×31mm | 32 | 32 |
| 3636W | 36×36mm | 36 | 36 |
| 3939W | 38×38mm | 39 | 39 |
| 4141W | 40×40mm | 41 | 41 |
| 4343W | 42×42mm | 43 | 43 |
| 4545W | 44×44mm | 45 | 45 |

QFP SERIES

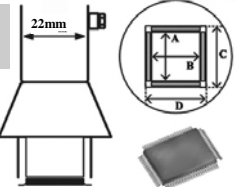

| MODEL # | IC SIZE | A (mm) | B (mm) | C (mm) | D (mm) |
|---------|-------------|--------|--------|--------|--------|
| 1125 | 10×10mm | 9 | 9 | 16 | 16 |
| 1126 | 14×14mm | 14 | 14 | 21 | 21 |
| 1127 | 17.5×17.5mm | 18 | 18 | 25 | 25 |
| 1128 | 14×20mm | 20 | 14 | 21 | 27 |
| 1129 | 28×28mm | 28 | 28 | 35 | 35 |
| 1215 | 42.5×42.5mm | 41 | 41 | 48 | 48 |
| 1261 | 20×20mm | 19 | 19 | 26 | 26 |
| 1262 | 12×12mm | 11 | 11 | 18 | 18 |
| 1263 | 28×40mm | 38 | 28 | 35 | 45 |
| 1264 | 40×40mm | 39 | 39 | 46 | 46 |
| 1265 | 32×32mm | 31 | 31 | 38 | 38 |

PLCC SERIES

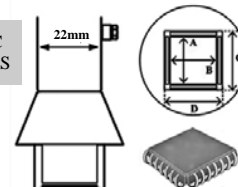

| MODEL # | IC SIZE | A (mm) | B (mm) | C (mm) | D (mm) |
|---------|-------------|--------|--------|--------|--------|
| 1135 | 17.5×17.5mm | 17.5 | 17.5 | 24.5 | 24.5 |
| 1136 | 20×20mm | 20 | 20 | 27 | 27 |
| 1137 | 25×25mm | 25 | 25 | 32 | 32 |
| 1138 | 30×30mm | 30 | 30 | 37 | 37 |
| 1139 | 7.3×12.5mm | 7.5 | 12.5 | 14.5 | 19.5 |
| 1140 | 11.5×11.5mm | 12 | 12 | 19 | 19 |
| 1141 | 11.5×14mm | 12 | 14 | 19 | 21 |
| 1188 | 9×9mm | 10 | 10 | 17 | 17 |
| 1189 | 34×34mm | 35.5 | 35.5 | 42.5 | 42.5 |

SOP SERIES

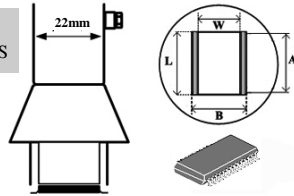

| MODEL # | IC SIZE | L (mm) | W (mm) | A (mm) | B (mm) |
|---------|------------|--------|--------|--------|--------|
| 1131 | 4.4×10mm | 11 | 3.8 | 9 | 10.3 |
| 1132 | 5.6×13mm | 16 | 4.7 | 14 | 11.7 |
| 1133 | 7.5×15mm | 17 | 6 | 15 | 13 |
| 1134 | 7.5×18mm | 20 | 6 | 18 | 13 |
| 1257 | 11×21mm | 22 | 11 | 20 | 18 |
| 1258 | 7.6×12.7mm | 12 | 7 | 10 | 14 |
| 1259 | 13×28mm | 30 | 12.5 | 28 | 19.5 |
| 1260 | 8.6×18mm | 20 | 7.7 | 18 | 14.7 |

SOJ SERIES

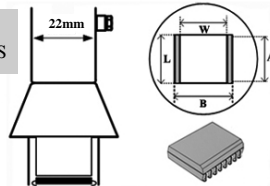

| MODEL # | IC SIZE | L (mm) | W (mm) | A (mm) | B (mm) |
|---------|---------|--------|--------|--------|--------|
| 1183 | 15×8mm | 17 | 7 | 15 | 14 |
| 1184 | 18×8mm | 20 | 9 | 18 | 16 |
| 1214 | 10×26mm | 27 | 11 | 25 | 18 |

TSOL SERIES

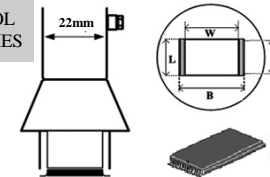

| MODEL # | IC SIZE | L (mm) | W (mm) | A (mm) | B (mm) |
|---------|----------|--------|--------|--------|--------|
| 1185 | 13×10mm | 11 | 11 | 9 | 18 |
| 1186 | 18×10mm | 12 | 17 | 10 | 24 |
| 1187 | 18.5×8mm | 11 | 18 | 9 | 25 |

BQFP SERIE

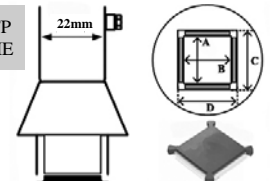

| MODEL # | IC SIZE | L (mm) | W (mm) | A (mm) | B (mm) |
|---------|---------|--------|--------|--------|--------|
| 1180 | 17×17mm | 17.2 | 17.2 | 24.2 | 24.2 |
| 1181 | 19×19mm | 18.2 | 18.2 | 25.2 | 25.2 |
| 1182 | 24×24mm | 23.2 | 23.2 | 30.2 | 30.2 |
| 1203 | 35×35mm | 34.2 | 34.2 | 41.2 | 41.2 |

AOYUE®

INT968A+

Deluxe Repairing System

INSTRUCTION MANUAL

Thank you for purchasing Aoyue INT 968A+ Repairing System.
It is important to read the manual before using the equipment.
Please keep manual in accessible place for future reference.



BASIC TROUBLESHOOTING GUIDE

This appliance can be used by children aged from 8 years and above and persons with reduced physical, sensory or mental capabilities or lack of experience and knowledge if they have been given supervision or instruction concerning use of the appliance in a safe way and understand the hazards involved. Children shall not play with the appliance. Cleaning and user maintenance shall not be made by children without supervision.

The specific instructions related to the safe operation of this appliance (as given in 7.12 of this standard) shall be collated together in the front section of the user instructions. The height of the characters, measured on the capital letters, shall be at least 3 mm. These instructions shall also available in an alternative format, e.g. on a website.

A fire may result if the appliance is not used with care, therefore:

- be careful when using the appliance in places where there are combustible materials ;
- do not apply to the same place for a long time;
- do not use in presence of an explosive atmosphere;
- be aware that heat may be conducted to combustible materials that are out of sight;
- place the appliance on its stand after use and allow it to cool down before storage;
- do not leave the appliance unattended when it is switched on.

Rohs

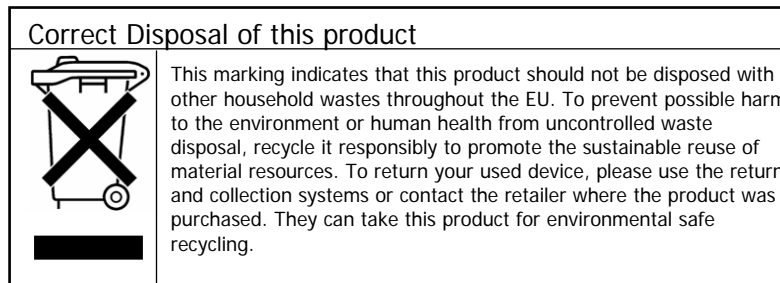

Manufacturer:

AOYUE INTERNATIONAL LIMITED

Jishui Industrial Zone, Nantou, Zhongshan City,
Guangdong Province, P.R.China
<http://www.aoyue.com>

PROBLEM 5: AIR PRESSURE LEVEL IS SIGNIFICANTLY LOW NO MATTER HOW HIGH THE AIRFLOW LEVEL IS CALIBRATED

Case 1: Check the mains voltage (AC power source). If the voltage level falls significantly low, about 15-20% lower than the standard, there will also be a noticeable drop in the air pressure level.

SOLUTION: Please refer to your local power service provider.

Case 2: The microcontroller might have detected the operating frequency incorrectly. The airflow level is noticeably weaker.

SOLUTION: Try to press the "Reset" button on the panel and let the device re-detect the proper operating frequency. Note that resetting the device will also reset all previously defined configurations.

PROBLEM 6: THE SOLDERING IRON DISPLAYS "Pen" or "Err"

Case 1 "Pen": Soldering Iron is not properly connected to the unit, unplug Soldering Iron and reattach to connector. Soldering Iron sensors may have been damaged and needs to be replaced.

Case 2 "Err": Soldering Iron cannot reach the desired set temperature, sensor could have been shorted due to wrong connection or heating element has reached the end of its life.

SOLUTIONS: Check internal pen connection, replace heating element.

PROBLEM 7: DISPLAY & OTHER DEVICE OPERATION ISSUES

SOLUTION: Try to press the "Reset" button on the device. Note that resetting the device will also reset all previously defined configurations.

OTHER PROBLEMS NOT MENTIONED:

Contact the vendor.

BASIC TROUBLESHOOTING GUIDE

PROBLEM 1: THE UNIT HAS NO POWER

1. Check if the unit is switched ON.
2. Check the fuse. Replace with the same type if fuse is blown.
3. Check the power cord and make sure there are no disconnections.
4. Verify that the unit is properly connected to the power source.

PROBLEM 2: TEMPERATURE DISPLAY IS ALWAYS ABOVE 500°C

Description: Constant display of above 500°C temperature from the panel C3 then displays a blinking “OFF” on display panels C2 and C3 after a few minutes.

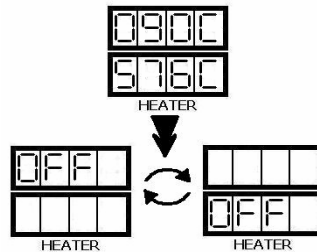

SOLUTION:

The thermal sensor may be broken and needs to be replaced.

PROBLEM 3: ACTUAL AIR TEMPERATURE IS NOT INCREASING

Description: Actual temperature reading is not increasing or decreasing based on desired level (set temperature). The panel will then display a blinking “OFF” on display panels C2 and C3 afterwards.

SOLUTION:

The heating element may be broken and needs to be replaced.

PROBLEM 4: BANNER OR PRODUCT NAME IS ALWAYS SCROLLING - THE UNIT IS NOT USABLE

Description: The product name is just always scrolling from the digital panel, rendering the device unusable.

SOLUTION: Press “Reset” from the panel. Note that resetting the device will also reset all previously defined configurations. If the problem persists, contact the vendor.

TABLE OF CONTENTS

| | |
|-----------------------------------|-------|
| PACKAGE INCLUSION | 3 |
| FUNCTIONS AND FEATURES | 4 |
| PRODUCT SPECIFICATIONS | 5 |
| CARE AND SAFETY PRECAUTIONS | 6 |
| PANEL CONTROLS | 7 |
| PREPARATION | 8 |
| OPERATING GUIDELINES | 9-14 |
| CARE AND USE OF THE TIP | 15 |
| MAINTENANCE | 16-17 |
| BASIC TROUBLESHOOTING GUIDE | 18-19 |
| REPLACEMENT AIR NOZZLES | 20 |

PACCKAGE INCLUSIONS

| | |
|--|--------|
| Main Station | 1 unit |
| Hot Air Gun and Hot Air Gun Holder | 1pc. |
| 1124 Air Nozzle | 1pc. |
| 1130 Air Nozzle | 1pc. |
| 1196 Air Nozzle | 1pc. |
| 1197 Air Nozzle | 1pc. |
| 1313 Air Nozzle | 1pc. |
| Soldering Iron with Smoke Absorber | 1pc. |
| 2660 Soldering Iron Holder** | 1pc. |
| Filter Vacuum Cap | 1pc. |
| Suction Vacuum Cap | 1pc. |
| Black Filter Pad (round) | 1pc. |
| G001 IC Popper | 1pc. |
| Power Cord | 1pc. |
| Instruction Manual | 1pc. |

** Kindly refer to soldering iron stand installation on page 8 for parts and instructions.

FUNCTION and FEATURES

- Micro-processor-controlled electro-static discharge (ESD) safe unit.
- Easy-to-use touch type panel controls with digital display for Hot Air Gun function.
- Environment-friendly repairing system that integrates Hot Air Gun, Soldering Iron, and Smoke Absorber in one package.
- Built-in smoke extractor that absorbs fumes created at the source.
- Knob type Soldering Iron temperature control for simple yet efficient working temperature selection.
- Digital control and display of Soldering Iron temperature.
- Sleep mode for soldering iron. Soldering Iron to go into sleep mode based on user defined duration.
- Solder Iron digital calibration, Soldering Iron tips can be calibrated + or -50 degrees. Easily adjust temperature offset with a few simple adjustments.
- Intelligent error-reporting mechanism. Detects and informs the personnel for problems with the sensor and heating element.
- Auto-cooling functionality. Hot Air Gun blows air to cool down the system to a safe temperature before turning OFF.
- Compatibility with various types of air nozzles.
- Compatibility with different kinds of soldering tips.

CARE and MAINTENANCE

SPARE PARTS LIST

| <u>PART#</u> | <u>NAME & SPECIFICATION</u> |
|---------------------|--|
| 10094 | Hot Air Gun heating element |
| 20094 | Hot Air Gun ceramic heating element |
| 30105S | Plastic handle of Hot Air Gun |
| S005 | Hot Air Gun complete handle |
| 20962 | Hot Air Gun metal pipe |
| P003 | Diaphragm pump |
| C009 | Soldering Iron heating element |
| 30126S | Plastic handle of Soldering Iron |
| B003A | Soldering Iron complete handle |
| 20170 | Tip enclosure |
| 30181X | Black Filter pads |

NOTE:

To ensure safety and quality, use only genuine parts for replacement.

CARE and MAINTENANCE

⚠ IMPORTANT: Unless otherwise directed, carry out these procedures with the power switched OFF and the power cord UNPLUGGED.

CARBON FILTER

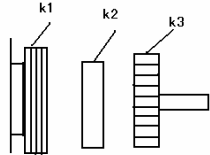

K1 — filter drawer
K2 — active carbon filter pads (30181X)
K3 — smoke absorption nozzle

- A filter device is installed at the vacuum outlet (see **D2** of panel controls reference page) . The filter pad should be cleaned and replaced regularly, depending on the frequency of use.

REPLACING THE HEATING ELEMENT

1. Loosen the 3 screws that secure the Hot Air Gun handle. The heating element is located in the middle part of the Hot Air Gun.
2. Slide off the plastic tube.
3. Disconnect the ground wire sleeve.
4. The Quartz glass and heat insulation are installed inside the pipe. Loosen the cable and remove the heating element.
5. Insert the new heating element and reconnect the terminal. Be careful not to rub or touch together the heating element wire.
6. Reconnect the ground wire after replacing the heating element.
7. Re-assemble the handle.

NOTE: The life expectancy of a heating element is 1 year under normal operating conditions.

SPECIFICATION

| | |
|------------------------------|------------------------------|
| Power Input : | available in 110V & 220V |
| Main Station Dimensions: | 188(w) x 126(h) x 250(d) mm |
| Weight: | 5.25Kg |
| SOLDERING IRON | |
| Power Consumption: | 70W |
| Temperature Range: | 200°C - 480°C |
| Heating Element : | Ceramic Heater |
| Output Voltage: | 24V |
| Tip to Ground Resistance: | Below 2 Ω |
| Tip to Ground Potential: | Below 2mV |
| HOT AIR | |
| Power Consumption: | 550W |
| Temperature Range: | 100°C - 480°C |
| Heating Element | Ceramic / Metal Heating Core |
| Nozzle to Ground Resistance: | Below 2 Ω |
| Pump/Motor Type: | Diaphragm Pump |
| Air Capacity: | 23 l /min (max) |
| SMOKE ABSORBER | |
| Vacuum Pressure: | 600mm Hg |

SAFETY PRECAUTIONS



CAUTION: Misuse can cause injury and other physical damage.
For your own safety, be sure to observe the following precautions.

- Temperature may reach as high as 480°C when unit is turned ON.
 - Do not use near paper, plastic, and flammable gases and materials.
 - Do not touch heated parts.
 - Do not touch metallic parts near the tip.
- Thermal Protector
 - The unit is equipped with auto shut-off ability when temperature gets too high. The unit will automatically switch back ON when the temperature has dropped to a safe level.
- Handle with Care
 - Never drop or sharply jolt the unit.
 - Contains delicate parts that may break if unit is dropped.
- Unplug the unit from the main power source if it will not be used for a long period.
 - Turn off power during breaks, if possible.
- Use only genuine replacement parts.
 - Turn-off power and let unit cool down before replacing any parts.
- Soldering process produces smoke; use the equipment on well-ventilated place.
- Do not modify or alter the unit in any manner, particularly the internal circuitry.

CARE and MAINTENANCE

1. Tip Temperature — High temperature shortens tip life and may cause thermal shock to other components. Always use the most appropriate temperature when soldering.

2. Cleaning — Always clean the soldering tip before using. Remove any residual solder or flux that are still adhering to the tip. Use a clean and moist cleaning sponge to remove unwanted residues. For better results our Aoyue 98 and 128 tip cleaners are great alternatives for wet sponges that cleans as good as wet sponges but does not lower tip temperature like wet sponges. Contaminants on the tip have many detrimental effects which may impact soldering performance — one being reduced heat conductivity.

3. After Use — Always clean the tip. Coat it with fresh solder after use. This protects the tip against oxidation.

4. Never allow the unit to stay idle at high temperature for long periods. This makes the tip prone to oxidation. Turn OFF the power switch if it will not be used for several hours. Unplug the main unit from the power source if possible.

CLEANING THE TIP

IMPORTANT: Performing this procedure extends life of the soldering tip.

1. Set the temperature to 250°C.
2. When the temperature has stabilized, clean the tip and check its condition. Replace the tip if it is badly worn or appears to be deformed.
3. If the solder plated part of the tip is covered with black oxide, apply fresh solder containing flux and clean the tip again. Repeat until all the oxide is removed. Coat the tip with fresh solder afterwards.
4. Remaining oxides such as the yellow discoloration on the tip shaft can be removed with isopropyl alcohol.



CAUTION: Never use file to remove residue from the tip.

OPERATING GUIDELINES

SOLDERING IRON MANUAL CALIBRATION

1. Set Soldering Iron to desired working temperature.
2. Wait a few minutes for the temperature to stabilize before checking the temperature difference with an external calibrated probe.
3. Access the manual calibration hole by removing the rubber cover of the calibration hole.
4. Use a small screw to slowly adjust the trimmer potentiometer thru the calibration hole.
5. When tip temperature has been recalibrated. Replace rubber cover into position.

SOLDERING IRON DISPLAY GUIDE

"Pen"— Soldering Iron is not detected.

"OFF"— Soldering Iron function is currently off.

"Hot"— Soldering Iron function is currently off but the Soldering Iron tip is still very hot.

"- - - -"— Soldering Iron is currently in sleep mode.

"t00"— Soldering Iron sleep timer adjustment mode, sleep timer off.

"t60"— Sleep timer adjustment mode, sleep timer set at 60 minutes.

"001 or -00"— Soldering Iron digital calibration adjustment mode.

"Err"— Soldering Iron error.

SOLDERING IRON SMOKE ABSORBER

1. Turn on Soldering Iron function and set to desired working temperature. Wait for Soldering Iron to reach set temperature.
2. Turn on the Smoke Absorber function switch.

Note: Smoke Absorber function cannot be enabled if the SMD rework function switch is turned "ON". To utilize the Smoke Absorber function the

CONTROL PANEL GUIDE

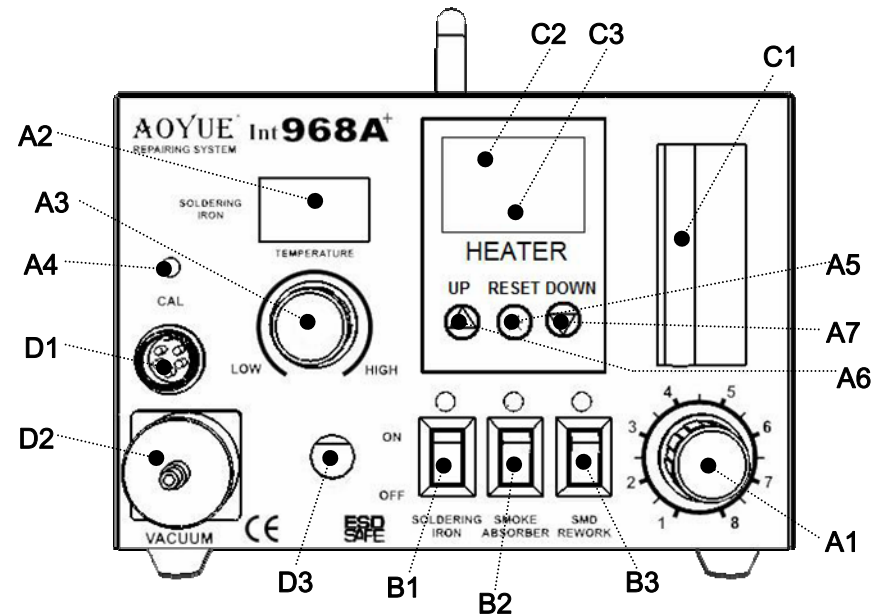

- A1 Air pressure knob
- A2 Soldering Iron temperature display
- A3 Soldering Iron temperature knob
- A4 Soldering Iron calibration hole.
- A5 Reset Hot Air Gun temperature
- A6 Hot Air Gun increase temperature adjustment button.
- A7 Hot Air Gun decrease temperature adjustment button.
- B1 Soldering Iron function switch
- B2 Smoke Absorber function switch
- B3 SMD rework function switch
- C1 Air pressure indicator
- C2 Set temperature display (Hot Air Gun)
- C3 Actual temperature display (Hot Air Gun)
- D1 Soldering Iron terminal
- D2 Smoke Absorber / Vacuum outlet
- D3 Hot Air Gun output

ASSEMBLY and PREPARATIONS

A. Main Power

1. Plug power cord into receptacle found at the back of the unit.

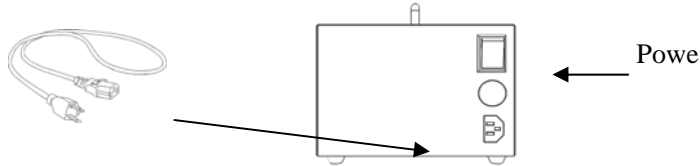

2. Switch on the main power switch to turn unit ON.

B. Soldering Iron

1. Attach the Soldering Iron to the main unit via the 6-pin output terminal, D1, found at the left side of the control panel.
2. Place the Soldering Iron to the Soldering Iron stand.

C. Soldering Iron Stand

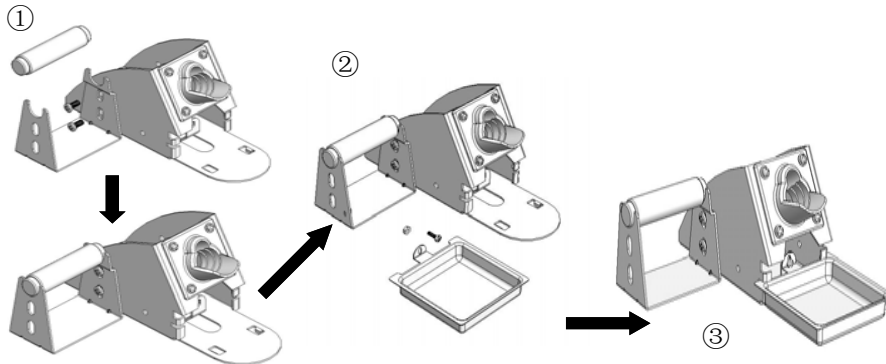

D. Smoke Absorber

Attach the smoke absorbing pen to the Smoke Absorber output terminal, D2, on the control panel. Make sure that the cord connections are free from any tangles.

E. Hot Air Gun

Place the Hot Air Gun in the stand to prepare for usage.

OPERATING GUIDELINES

- The Soldering Iron display A2 will turn to “-##” or “0##” , indicating it is now on digital calibration mode.
 - Turn the Soldering Iron adjustment knob to set calibration to “-00”. This resets the calibration to zero.
 - let system save the calibration value into the memory by waiting for a few seconds until the system automatically jumps out of the calibration mode.
3. Set Soldering Iron to desired working temperature.
 4. Wait a few minutes for the temperature to stabilize before checking the temperature difference with an external calibrated probe.
 5. If external calibrated probe shows a higher number than the 968A+ Soldering Iron displayed actual temperature we input a positive calibration number. If external calibrated probe shows a lower number than the displayed 968A+ Soldering Iron actual temperature we input a negative calibration number.
 6. Again access the calibration mode of the Soldering Iron:
 - Ensure that the SMD and Smoke Absorber function switch is off.
 - Ensure that Soldering Iron function switch is on.
 - Press and hold the hot air temperature increase button A6.
 - The Soldering Iron display A2 will turn to “-##” or “0##” , indicating it is now on digital calibration mode.
 - Turn the Soldering Iron adjustment knob to set the desired calibration value.
 - Let system save the desired calibration value into the memory by waiting for a few seconds until the system automatically jumps out of the calibration mode.
 7. Calibration numbers can be adjusted from negative 50 to positive 50. If the digital calibration number is insufficient for calibration.

OPERATING GUIDELINES

- To let system save the desired sleep timer value into the memory, simply let go of the adjustment knob and the system will automatically save the value into CPU memory.
3. Turn on the Soldering Iron function switch to start using the Soldering Iron.
 4. The sleep timer will start counting down once the Soldering Iron function switch is turned ON and no adjustments are made to Soldering Iron set temperature.
 5. When the timer expires, the Soldering Iron will shut down its heater and display three dashes "- - -". This indicates the Soldering Iron is in sleep mode.
 6. To wake the Soldering Iron simply adjust the temperature knob A3.
 7. To disable the sleep timer simply set the sleep timer duration to 0.
 8. Access and disable the sleep feature of the Soldering Iron:
 - Turn Soldering Iron, SMD and Smoke Absorber function switch off.
 - Press and hold the hot air temperature increase button A6.
 - The Soldering Iron display A2 will turn to "t##" , indicating it is now on sleep timer adjustment mode.
 - Turn the Soldering Iron adjustment knob completely counter clockwise to set timer to "t00".
 - let system save the desired sleep timer value into the memory.

SOLDERING IRON DIGITAL CALIBRATION

1. The Soldering Iron has a digital calibration feature that allows the user to easily adjust the temperature offset of the Soldering Iron + or—50 degrees.
2. Reset the calibration number of the Soldering Iron:
 - Turn SMD and Smoke Absorber function switch off.
 - Turn Soldering Iron function switch on.
 - Press and hold the hot air temperature increase button A6.

OPERATING GUIDELINES

SMD REWORKING

1. Ensure All function switches (B1,B2,B3) are in off position.
2. With the unit plugged to the main power source, turn on the system by switching the main power switch on. The panel should initially display the product name in a scrolling manner and display OFF on panel C2 after.

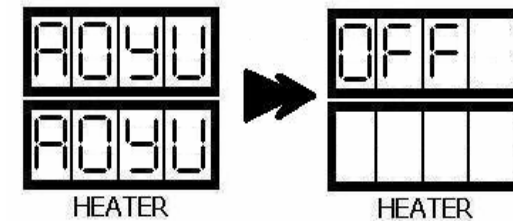

NOTE: The product name may scroll more than once upon plugging the system to the power source. The system is trying to determine the appropriate operating frequency based on the user location. See Basic Troubleshooting Guide (page 14-15).

3. Turn ON the "SMD Rework" function switch, B3.
4. The system will start to blow hot air and increase the temperature to 90°C, by factory default setting. Display panel, C2, shows the user-defined (set) temperature while display panel, C3, shows the actual temperature of the system.
5. Adjust air pressure by turning knob A1. It is recommended to keep the knob setting at 3 or above. It is also advised to adjust the airflow level first before increasing the air temperature to avoid building of too much heat on the Hot Air Gun thus burning the heating element.

NOTE: If air pressure knob is set to minimum upon switching the SMD Rework ON, the system will automatically run at average airflow to protect the device from excessive heat. The user will gain full control once the knob has been adjusted to the desired airflow level.

OPERATING GUIDELINES

6. Set the desired air temperature using buttons A6 and A7.
7. You may start reworking as soon as the desired temperature is reached. Refer to display panel C3 to verify.
8. When reworking is completed, turn off the **“SMD Rework”** function switch. The auto-cooling functionality will commence if the system detects a temperature higher than 95°C. It will blow at full speed to accelerate the cooling down of the Hot Air Gun. The auto-cooling functionality will stop when the temperature of the Hot Air Gun reaches about 95°C or below, as shown from the actual temperature display panel, C3. The system will then switch off and display an “OFF” message from user-defined temperature display panel, C2.

NOTE: *Make sure the smoke absorption functionality is switched OFF when using the equipment for SMD Rework.*

SOLDERING IRON

1. With the unit plugged to the main power source and main power switch in the ON position, ensure that the Soldering Iron is properly connected to the receptacle, D1.
2. The Soldering Iron display A2 will show the word “OFF” indicating the Soldering Iron function is turn off.
3. To use the Soldering Iron turn ON the **“Soldering Iron”** function switch, B1.
4. The Soldering Iron display A2 will briefly show the current set temperature then switch to displaying the actual temperature.
5. When we use the adjustment knob, A3, to set the desired soldering temperature. The digital display A2 will show the current set temperature based on the knob position.

OPERATING GUIDELINES

6. After a few seconds the digital display A2 will switch to showing the actual temperature. You may start soldering when the desired temperature has been reached. The small dot located at the end of the number displayed in A2 signifies the heater regulation. When the small dot starts blinking on and off the system has reached the desired set temperature.
7. After usage turn off the Soldering Iron function switch.
8. If the Soldering Iron tip is still higher than 100 degrees, the Soldering Iron display will show the word “Hot” indicating the Soldering Iron is still hot to caution users.
9. When the Soldering Iron tip’s temperature has fallen to manageable level the display will show the word “OFF”
10. Switch ON the **“Smoke Absorber”** function switch, B2, to activate the smoke absorption functionality.

NOTE: *Turn the “Smoke Absorber” ON only after the soldering iron reached the desired (set) temperature. This is to avoid affecting the temperature increase of the soldering iron in terms of heating time.*

SOLDERING IRON SLEEP TIMER

1. The Soldering Iron has a sleep feature that allows the Soldering Iron to go into sleep mode depending on user programmed duration.
2. To access and enable the sleep feature of the Soldering Iron:
 - Turn Soldering Iron, SMD and Smoke Absorber function switch off.
 - Press and hold the hot air temperature increase button A6.
 - The Soldering Iron display A2 will turn to “t##” , indicating it is now on sleep timer adjustment mode.
 - Turn the Soldering Iron adjustment knob to select desired sleep time in minutes.